

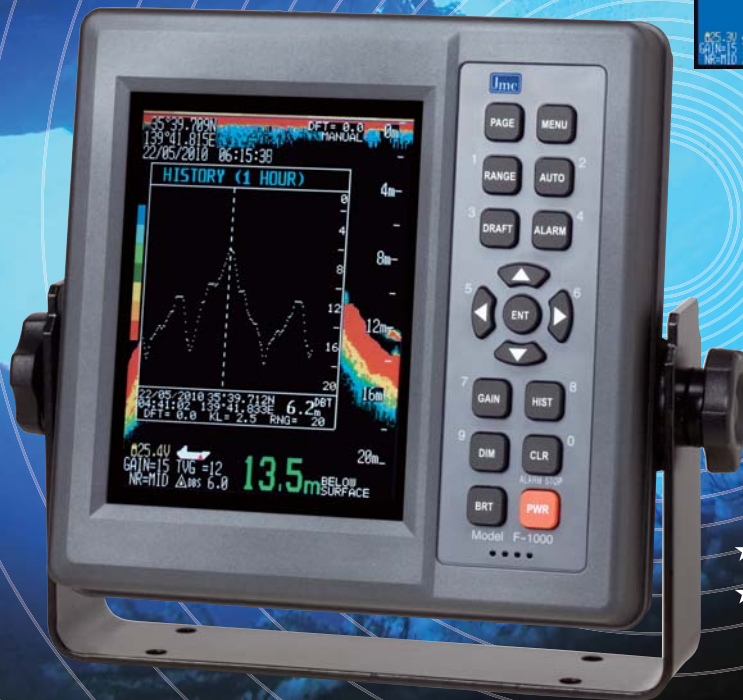

Model F-1000



- ★ Type-approved by CCS and RMRS
- ★ Compliance with MED certified by BSH with wheel mark for EU flag vessels



Featuring:

IMO resolution-compliant low-cost single-frequency navigation sounder housed in electrostatically-shielded compact ABS plastic cabinet

Certified to comply with EU Marine Equipment Directive (MED) and other relevant international standards for wheel mark certification

7-analog color, easy-on-the-eye echogram across 5.7" long-life LED-backlit daylight-readable LCD screen

Fully automatic operation, tracking bottom contour with appropriate range, receiver gain and TVG settings. Manual override is possible.

Store up to 12 hours of sounding history for off-line applications, together with date, time stamping and with position coordinates (optional GPS sensor with NMEA data outputs required).

Eexternally acknowledgeable navigational and failure alarms by IEC-defined software commands

Password-protected to prevent unauthorized changes to important system parameter settings

Optional monochrome graphic printer available for simulated paper-recording type sounder operation

Specifications:

Transducer Frequency: 50 or 200kHz (to be user-specified at time of ordering)

Screen: 5.7" LED-backlit LCD, daylight-viewing, QVGA (320X240 pixel) resolution

Depth Ranges: 5 to 1000m in 8-range steps, automatic/manual selection

Fathom/braccia/foot calibrations are selectable.

Minimum Detectable Depth: Better than 50cm (200kHz), 1m (50kHz)

Transmit Power: Approx. 600W RMS with automatic selection of optimum pulse length for range in use

Soundings Data Storage: Up to 12 hours in non-volatile memory; retrievable from PC via RS-422 port

Digital Interfaces: 2XRS-422 ports, 1X 8-pin I/O data port (NMEA-0183/RS-232C)

Power Requirements: 11 to 40VDC, approx. 12W

Cabinet Weight: Approx. 1.2kg (with mounting bracket)

Environment: Compliant with IEC 60945-2002 (protected category), IPX4

Compass Safe Distances: 1.00m (standard), 0.55m (steering)

Major Compliant Standards: IMO Resolutions MSC.74(69) & A.694(17), IEC 60945, IEC 61162-1, ISO 9875, MED 2011/75/EU

NOTE: Specifications are subject to change without notice or obligation.

Dimensions (in mm)

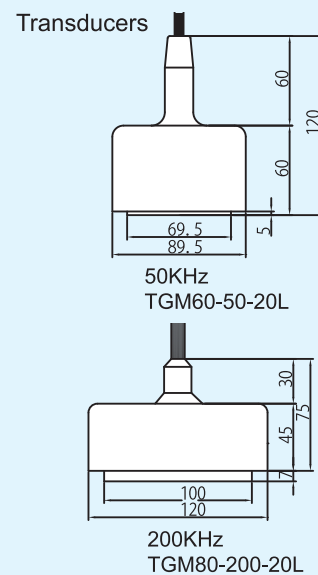
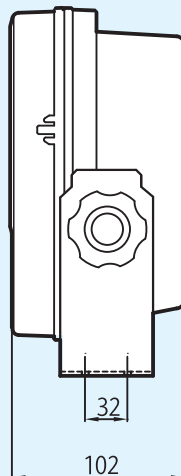
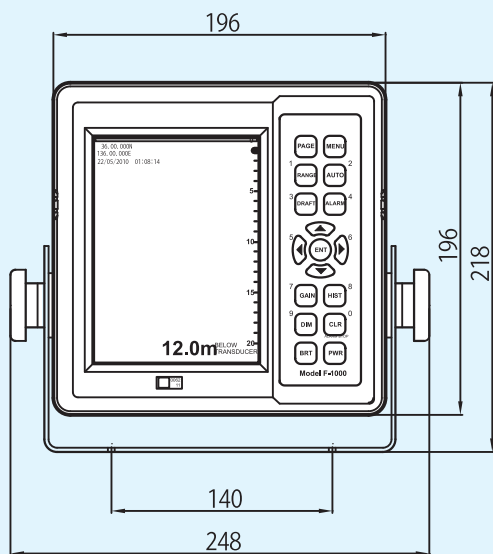

External Connections to Rear Panel

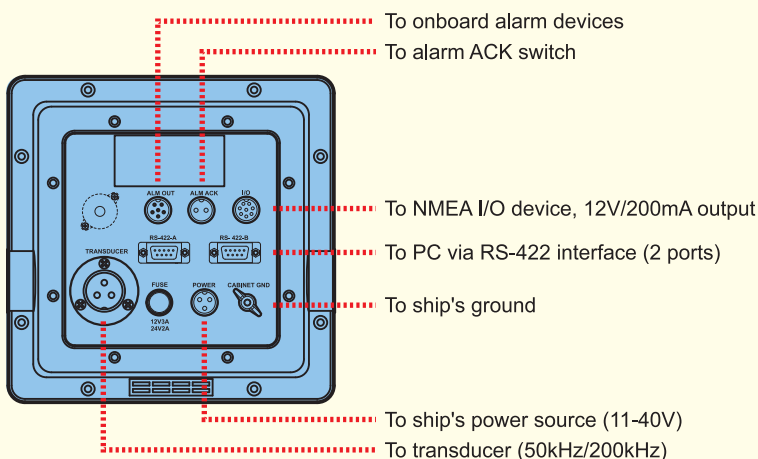

Standard Equipment

(1 pc. each, except as specified):

- F-1000 Navigation Sounder
- Transducer (50 or 200kHz) with 20m cable
- Power Supply Cable (3m, terminated in 3-pin plug)
- Mounting Hardware (bracket) with 2 pcs. knobs
- Plugs:
 - 3-pin plug for transducer cable
 - 2-pin plug for ALARM ACK receptacle
 - 6-pin plug for ALARM OUT receptacle
 - 8-pin plug for I/O receptacle
- Fuses (2A/24V, 3A/12V, mini type, 2 pcs. each)
- User's Manual